

Fall 11-2-2015

Impact of closed and continuous processing on biopharmaceutical facility layouts

Marc Pelletier

CRB Consulting Engineers, marc.pelletier@crbusa.com

Follow this and additional works at: http://dc.engconfintl.org/biomanufact_ii



Part of the [Biomedical Engineering and Bioengineering Commons](#)

Recommended Citation

Marc Pelletier, "Impact of closed and continuous processing on biopharmaceutical facility layouts" in "Integrated Continuous Biomanufacturing II", Chetan Goudar, Amgen Inc. Suzanne Farid, University College London Christopher Hwang, Genzyme-Sanofi Karol Lacki, Novo Nordisk Eds, ECI Symposium Series, (2015). http://dc.engconfintl.org/biomanufact_ii/73

This Conference Proceeding is brought to you for free and open access by the Proceedings at ECI Digital Archives. It has been accepted for inclusion in Integrated Continuous Biomanufacturing II by an authorized administrator of ECI Digital Archives. For more information, please contact franco@bepress.com.

WE LISTEN. WE DELIVER.

Future Facility
Presentation



**Integrated
Continuous
Biomanufacturing II**

Berkeley, CA
November 1, 2015

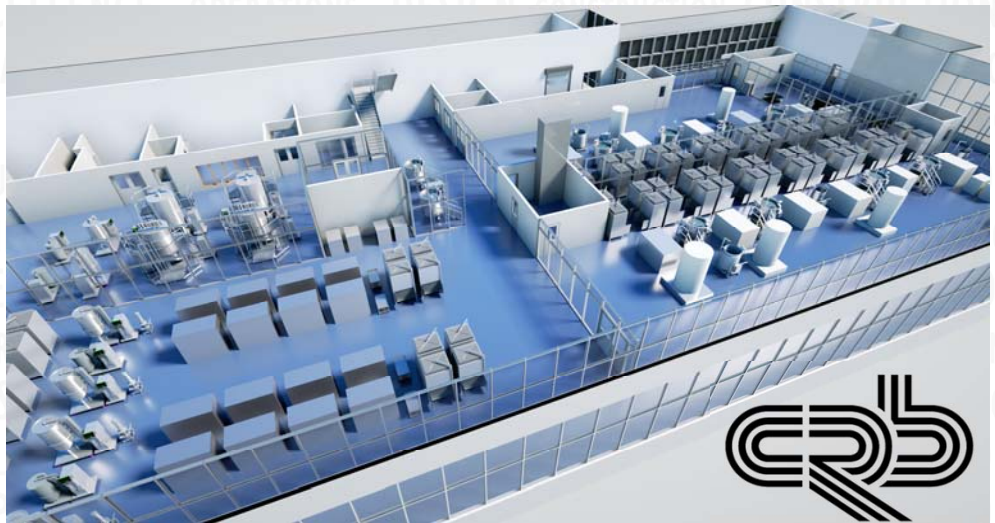

CONSULTING ■ DESIGN ■ CONSTRUCTION ■ COMMISSIONING ■ QUALIFICATION



THE RELENTLESS PURSUIT OF SUCCESS. YOURS.™

Future Facility™

*Applying Closed Concepts
The Incredible Shrinking Facility*

1980s Multiproduct Facility: CanMAb 1 & CanMAb 2



User Requirement

- 500 Kg CanMAb 1 & 1500 Kg Can MAb 2 required/yr
- Titer = 4 g/L – Net recovery = 52% (purification, filling & sampling)
- 10K bioreactors are maximum size that will fit in proposed building
- 12-14 day production (batch), 60 day perfusion @ 1 g/L
- Maximum ProA column size is 2m
- Max of 3 chromatography cycles in 24 hours
- BRX → Centrifuge → Depth → 0.2 μ → ProA → Chrom 2 → Chrom 3
→ nanofiltration → UF/DF → 0.2 μ bulk substance fill

1980s Traditional Multiproduct Facility



CanMAb 1 & 2

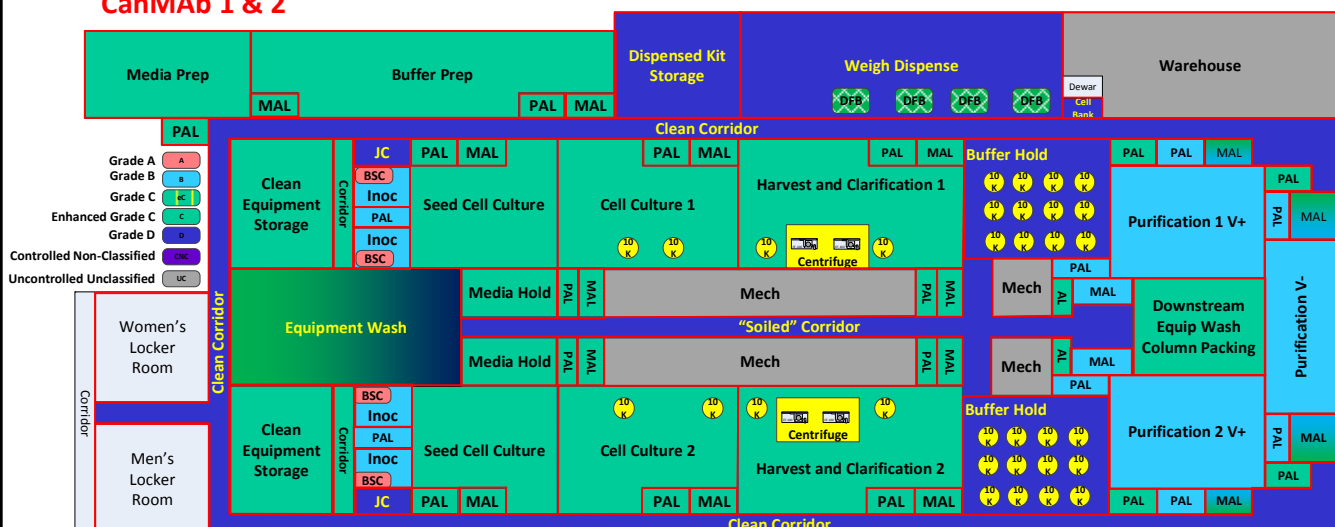

1980s Traditional Multiproduct Facility



CanMAb 1 & 2

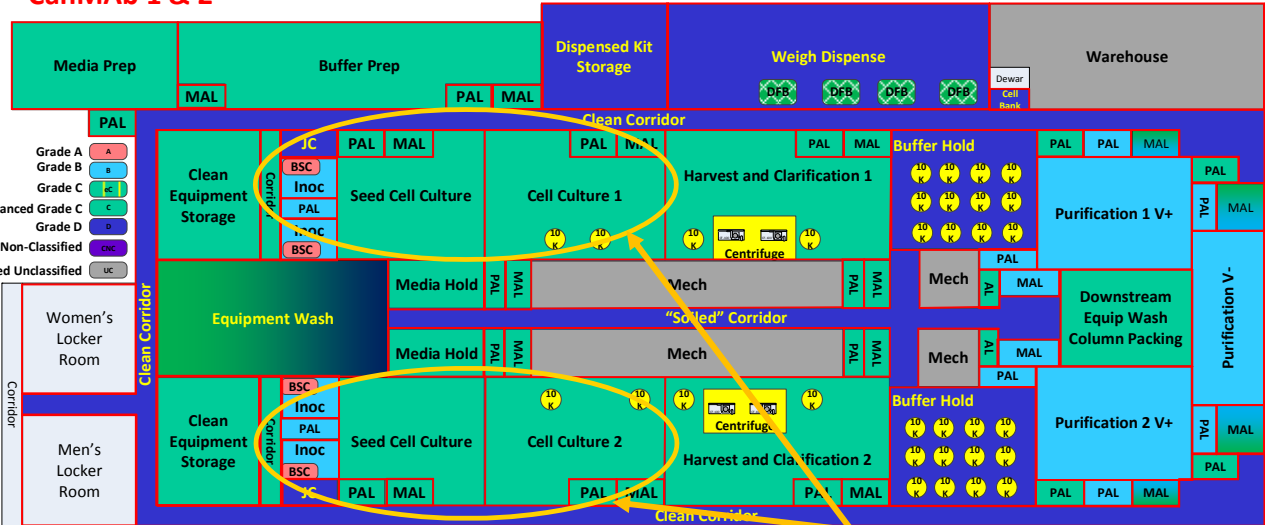

Separation of cell culture areas

1980s Traditional Multiproduct Facility



CanMAb 1 & 2

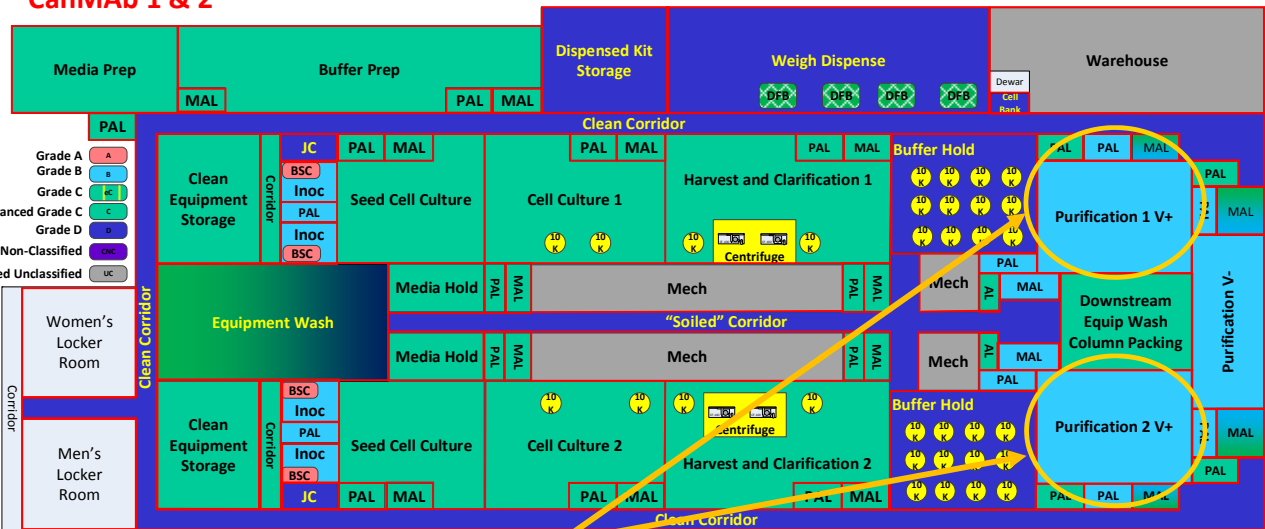

Separation of Purification areas

1980s Traditional Multiproduct Facility



CanMAb 1 & 2

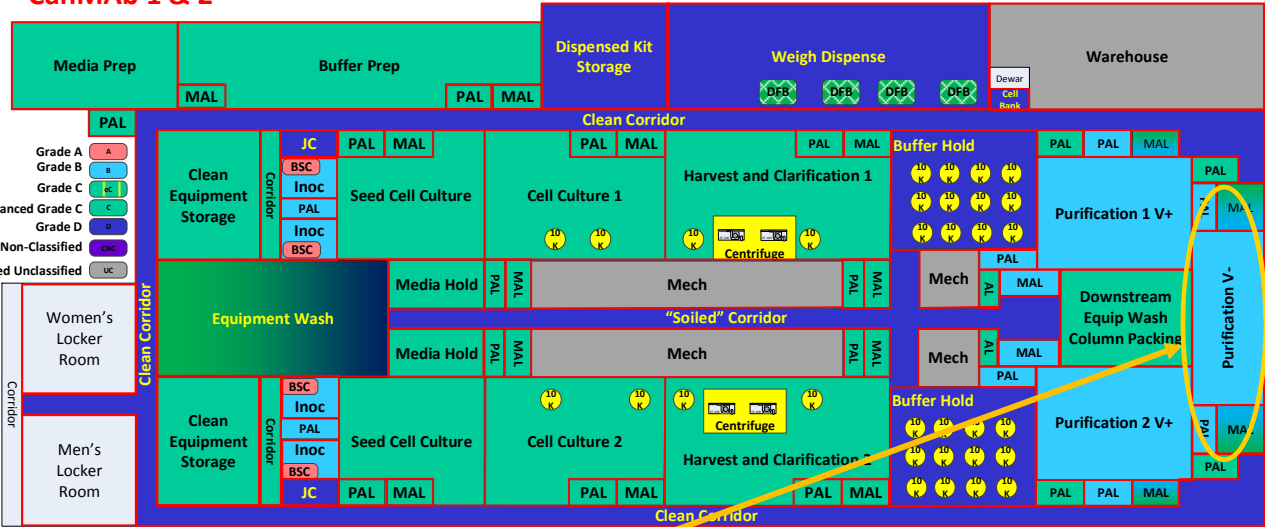

Single UF/DF – Bulk Fill area

1980s Traditional Multiproduct Facility



CanMAb 1 & 2

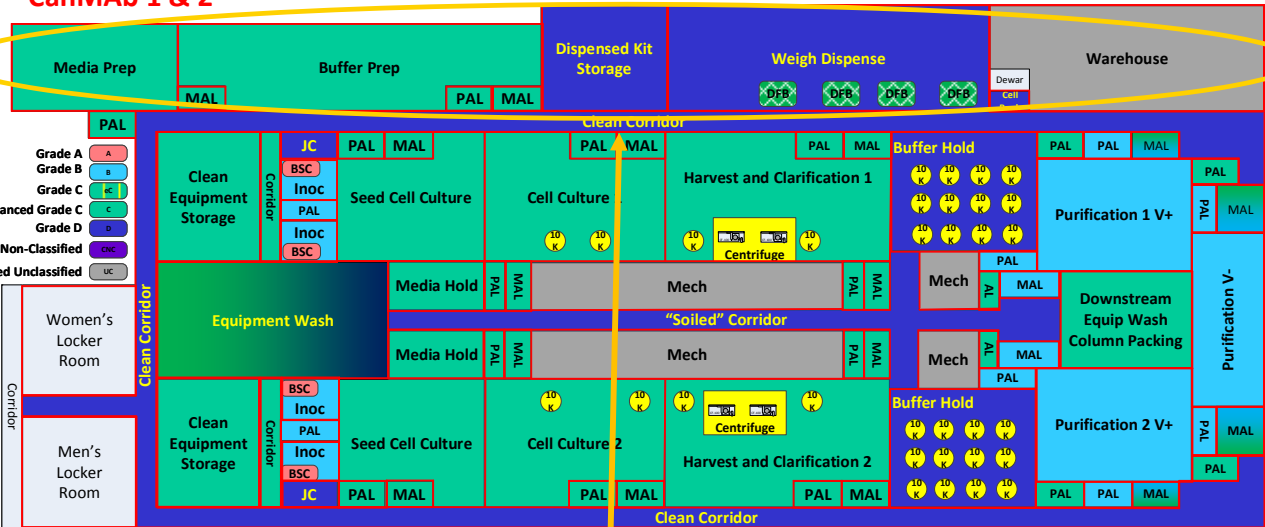

Single Media Prep, Buffer Prep, Weigh Dispense, Warehouse

1980s Traditional Multiproduct Facility



CanMAb 1 & 2

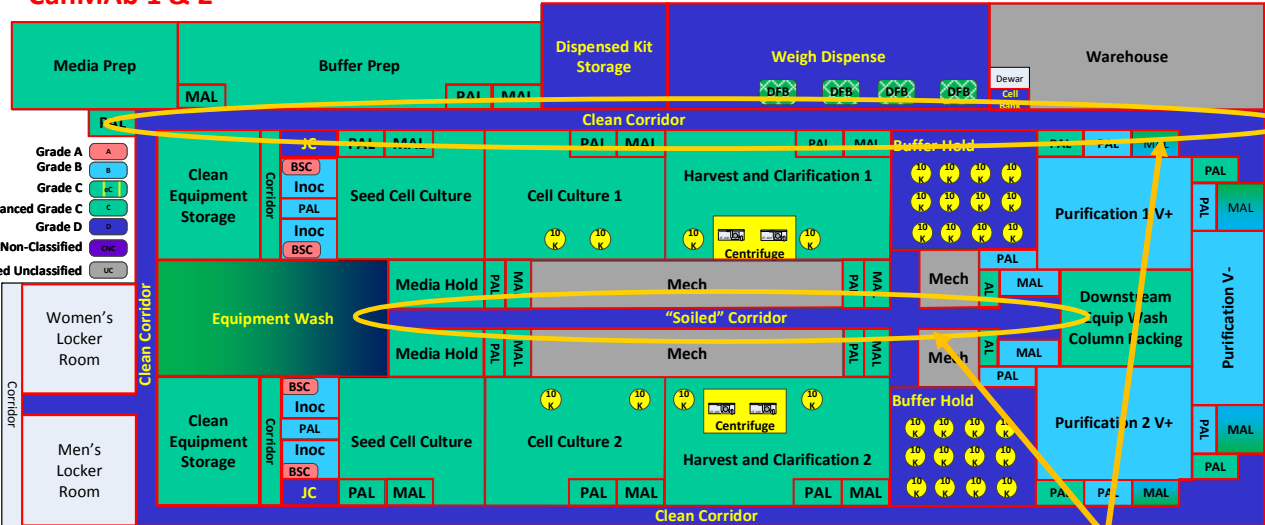

Two Corridor System

1980s Traditional Multiproduct Facility



CanMAb 1 & 2

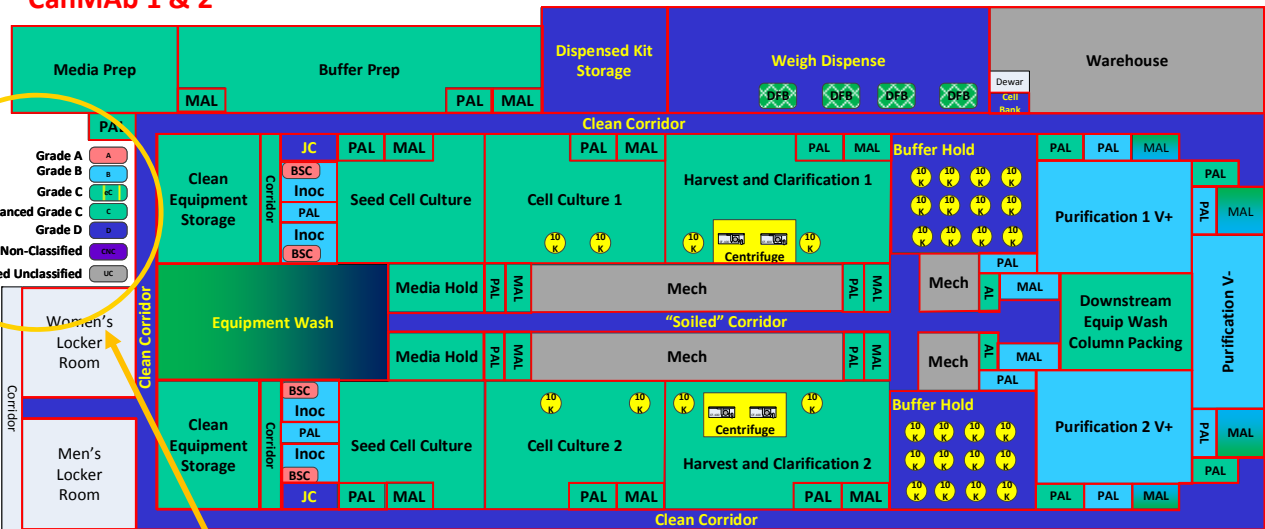

Highly classified clean rooms

2015 Upgrade Required – Changing Needs



User Requirement

- Higher titers expected. Other products expected.
- Segregation of Products required.

Upstream Process: Need for rolling changeover



CanMAb 1 & 2

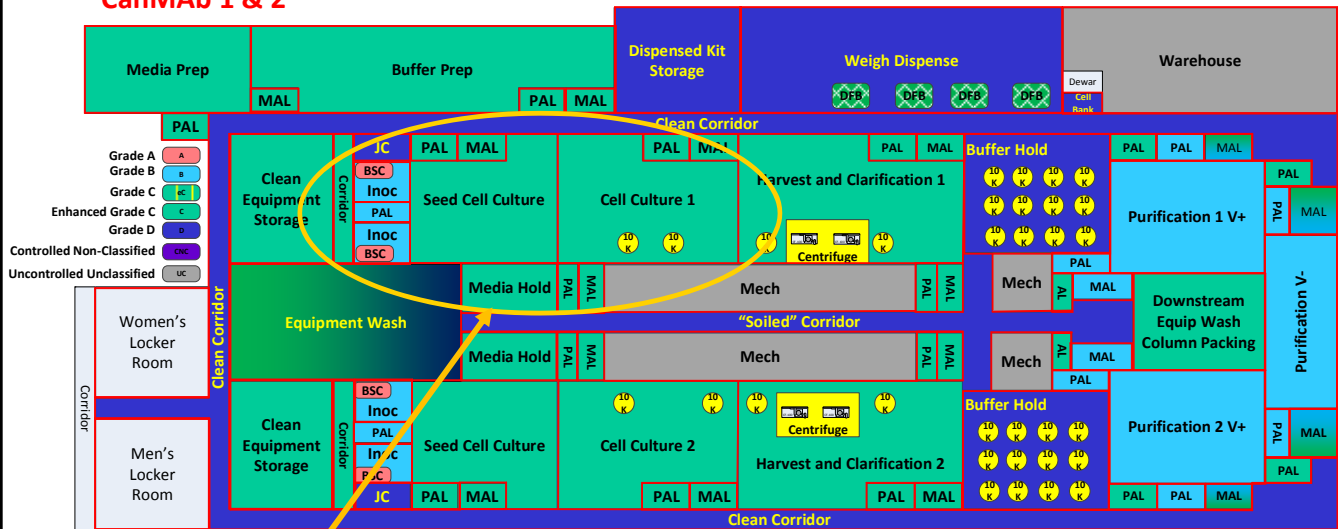

Accommodate rolling changeover

Upstream Process: Need for rolling changeover



CanMAb 1 & 2

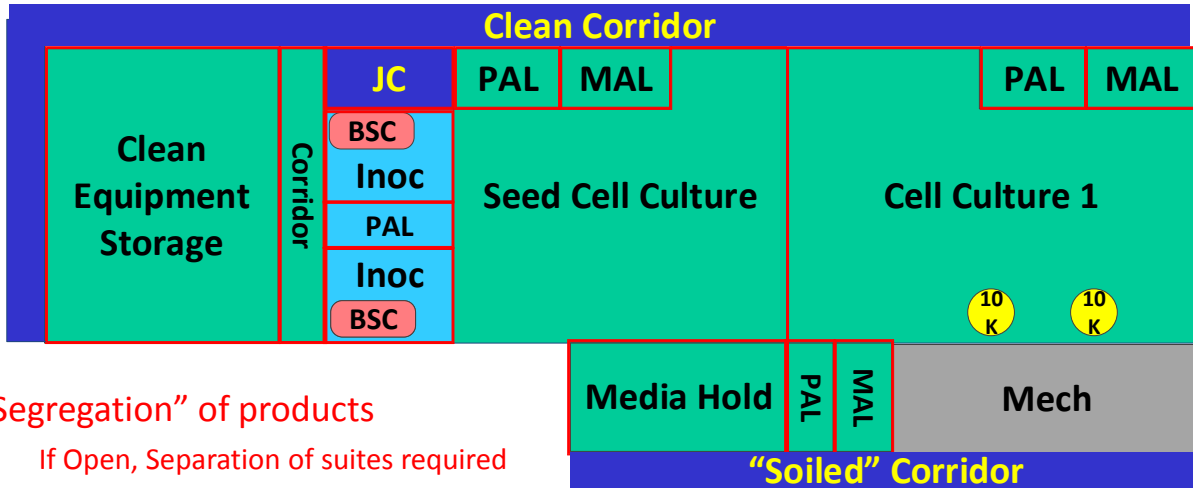

“Segregation” of products
 If Open, Separation of suites required

Upstream Process: Need for rolling changeover



CanMAb 1 & 2

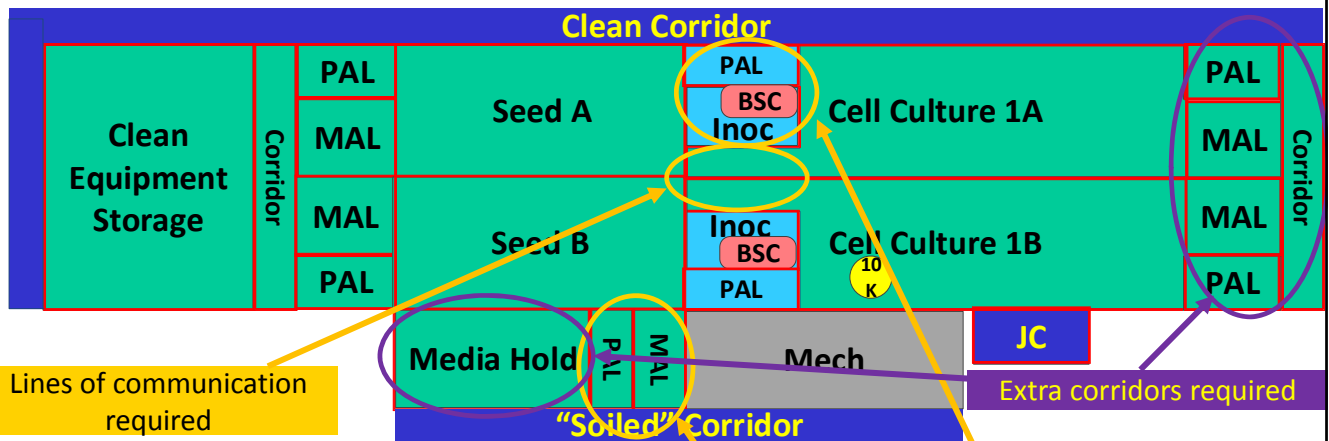

“Segregation” of products
 If Open, Separation of suites required

Downstream



CanMAb 1 & 2

Only used 1 day per week

Issue: Rolling turnover

“Segregation” of products
If Open, Separation of process steps required

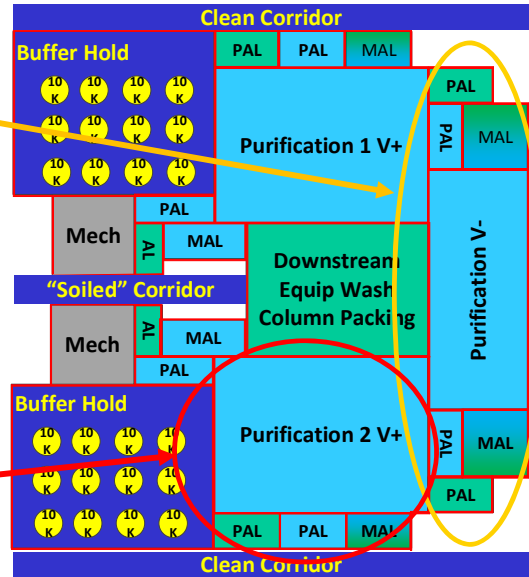

Downstream Process: Need for rolling changeover

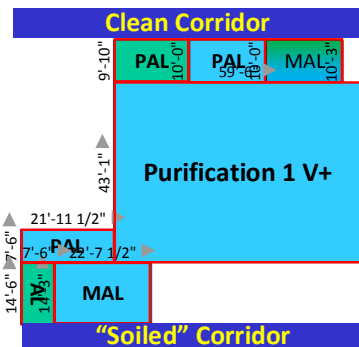

If risk of carryover or contamination from the environment is possible → Complete spatial segregation is required.

Multiple A/L

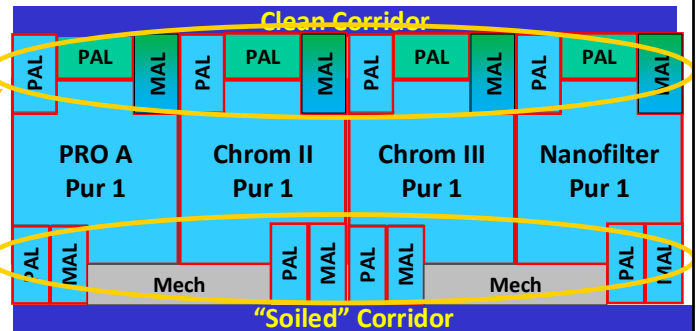

Open Processing Thinking

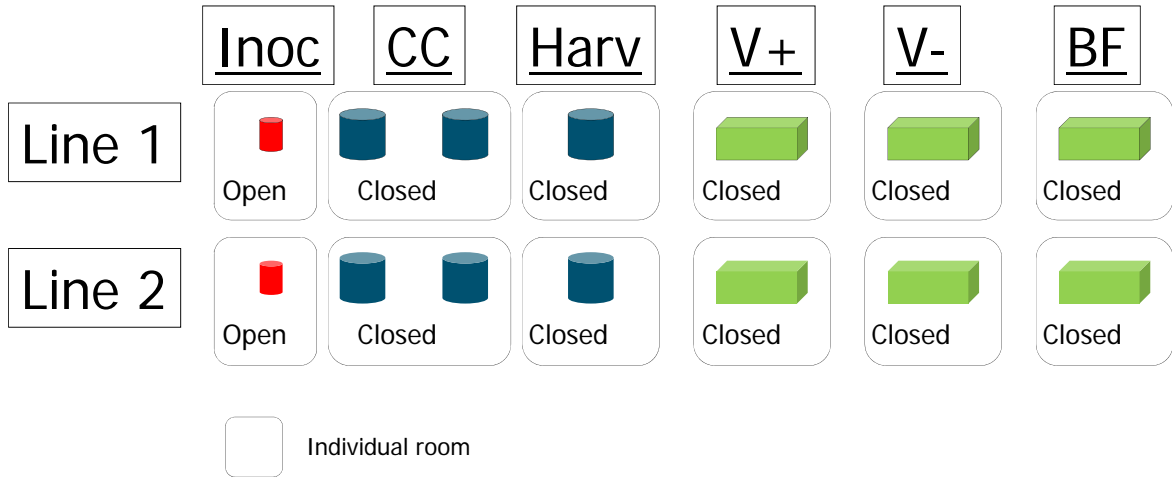

Harmonization of Regulatory Agencies



Pharmaceutical Inspection Convention (PIC/S)



PHARMACEUTICAL INSPECTION CONVENTION
PHARMACEUTICAL INSPECTION CO-OPERATION SCHEME

PE 009-10 (Part II)
1 January 2013

GUIDE TO GOOD MANUFACTURING PRACTICE FOR MEDICINAL PRODUCTS PART II

Developed by the International Conference on Harmonisation (ICH) of Technical Requirements for Registration of Pharmaceuticals for Human Use

© PIC/S January 2013
Reproduction prohibited for commercial purposes.
Reproduction for internal use is authorized,
provided that the source is acknowledged.

Editor: PIC/S Secretariat
14 rue de Valenciennes
CH-1207 Geneva
e-mail: info@picscheme.org
web site: <http://www.picscheme.org>

PE 009-10 (Part II) 1 January 2013



PHARMACEUTICAL INSPECTION CONVENTION
PHARMACEUTICAL INSPECTION CO-OPERATION SCHEME

PE 009-9 (Annexes)
1 September 2009

GUIDE TO GOOD MANUFACTURING PRACTICE FOR MEDICINAL PRODUCTS ANNEXES

© PIC/S September 2009
Reproduction prohibited for commercial purposes.
Reproduction for internal use is authorized,
provided that the source is acknowledged.

Editor: PIC/S Secretariat
14 rue de Valenciennes
CH-1207 Geneva
e-mail: info@picscheme.org
web site: <http://www.picscheme.org>

PE 009-9 (Annexes) 1 September 2009

Annex 2 Manufacture of biological medicinal products for human use

ANNEX 2

MANUFACTURE OF BIOLOGICAL MEDICINAL PRODUCTS FOR HUMAN USE

SCOPE

The methods employed in the manufacture of biological medicinal products are a critical factor in shaping the appropriate regulatory control. Biological medicinal products can be defined therefore largely by reference to their method of manufacture. Biological medicinal products prepared by the following methods of manufacture will fall under the scope of this annex:

- a) Microbial cultures, excluding those resulting from r-DNA techniques.
- b) Microbial and cell cultures, including those resulting from recombinant DNA or hybridoma techniques.
- c) Extraction from biological tissues.
- d) Propagation of live agents in embryos or animals.

(Not all of the principles of this guideline may necessarily apply to products in category a.)

Note: In drawing up this guidance, due consideration has been given to the general requirements for manufacturing establishments and control laboratories proposed by the WHO.

The present guidance does not lay down detailed requirements for specific classes of biological products.

PRINCIPLE

The manufacture of biological medicinal products involves certain specific considerations arising from the nature of the products and the processes. The way in which biological medicinal products are produced, controlled and administered make some particular precautions necessary.

Unlike conventional medicinal products, which are reproduced using chemical and physical techniques capable of a high degree of consistency, the biological medicinal products manufactured by these methods include: vaccines, plasmids, antibodies, hormones, cytokines, enzymes and other products of eukaryotic (including prokaryotic) bodies and products derived from r-DNA.

PE 009-9 (Annexes) -10- 1 September 2009

Open Processing Thinking

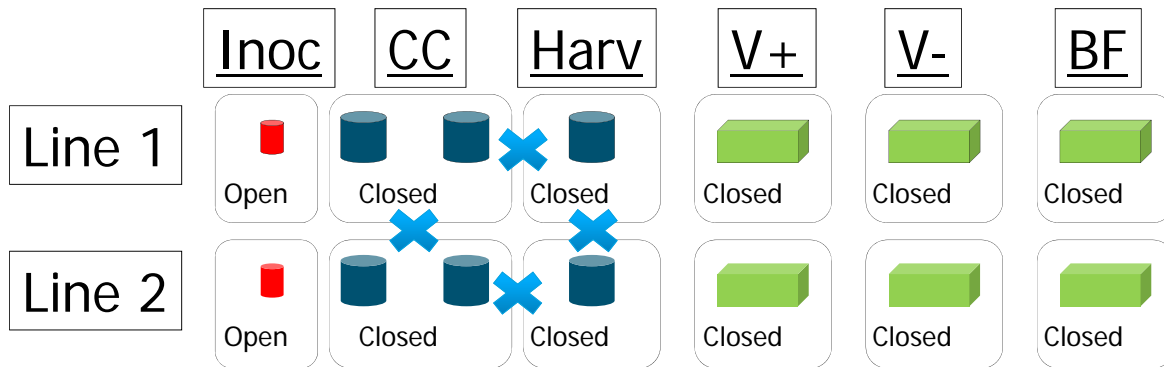

ANNEX 2

MANUFACTURE OF BIOLOGICAL MEDICINAL SUBSTANCES AND PRODUCTS FOR HUMAN USE

Item 11. Simultaneous production in the same area using closed systems may be acceptable for products such as monoclonal antibodies and products prepared by r-DNA techniques.

Closed Processing Thinking 1

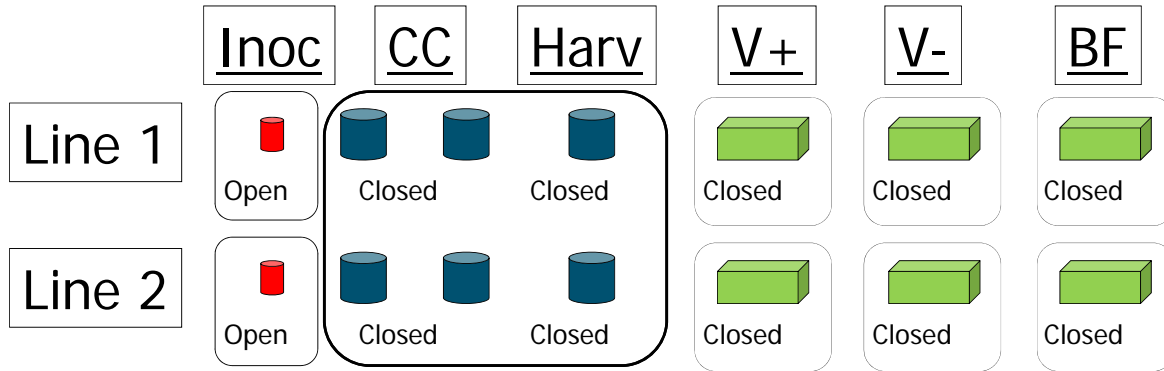

ANNEX 2

MANUFACTURE OF BIOLOGICAL MEDICINAL SUBSTANCES AND PRODUCTS FOR HUMAN USE

Item 11. Simultaneous production in the same area using closed systems may be acceptable for products such as monoclonal antibodies and products prepared by r-DNA techniques.

1980s Traditional Facility

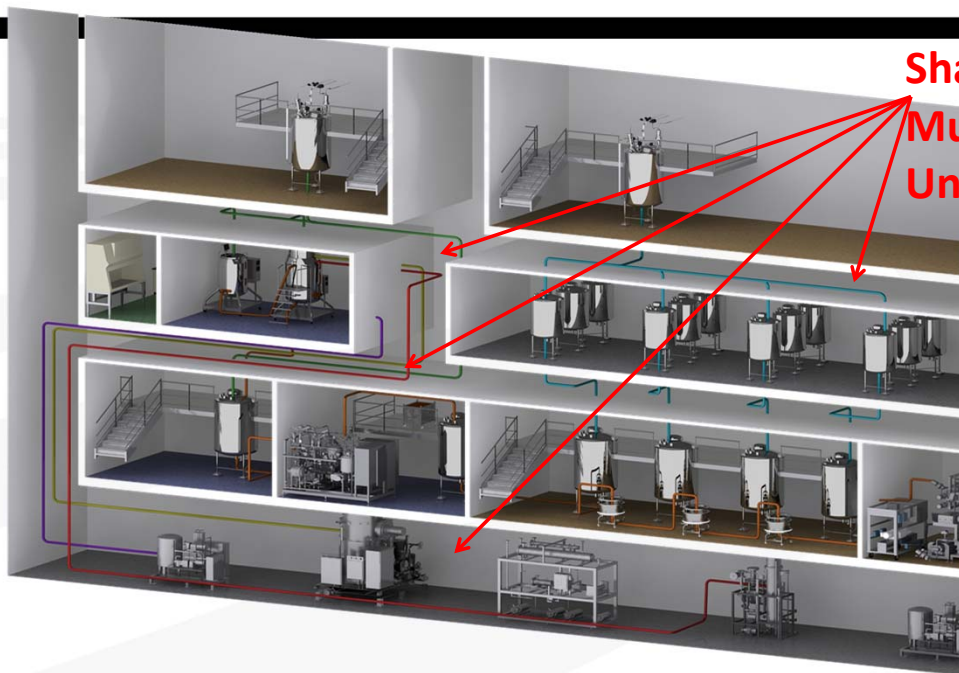

**Shared
Multiproduct
Unclassified!**

Impact of closed bioreactors



CanMAB 1 & 2

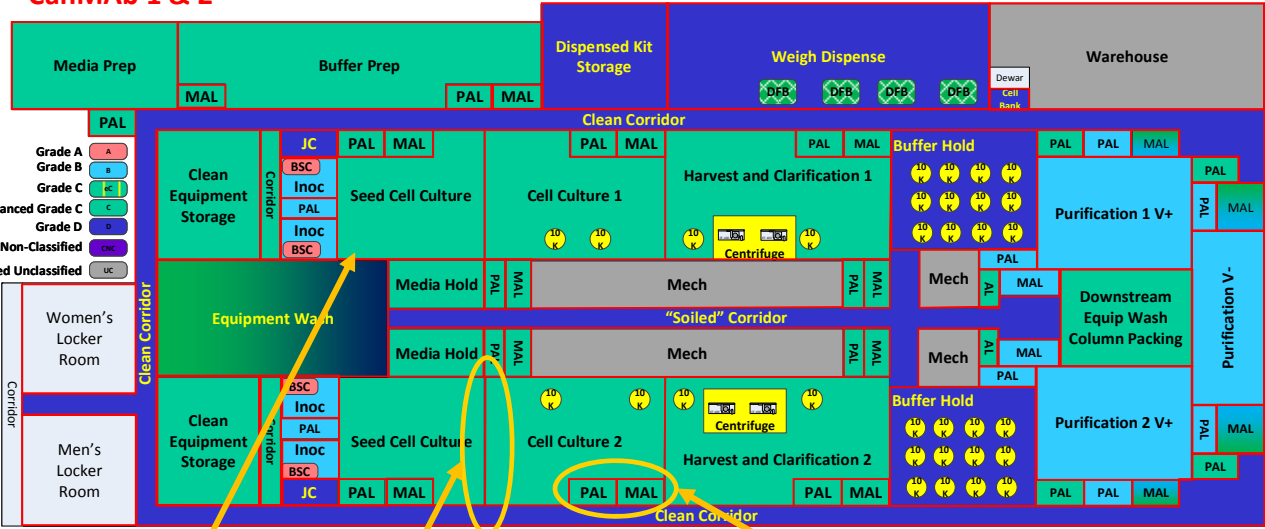

De-classify areas Remove segregation Remove A/L

Impact of closed bioreactors

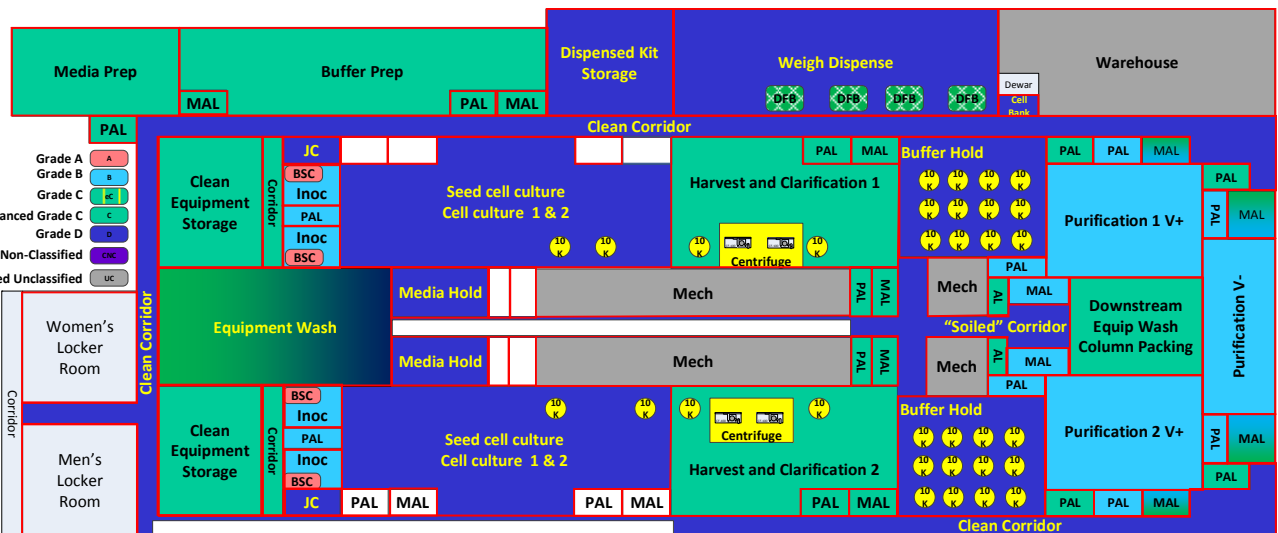

Isolating inoculum prep functions

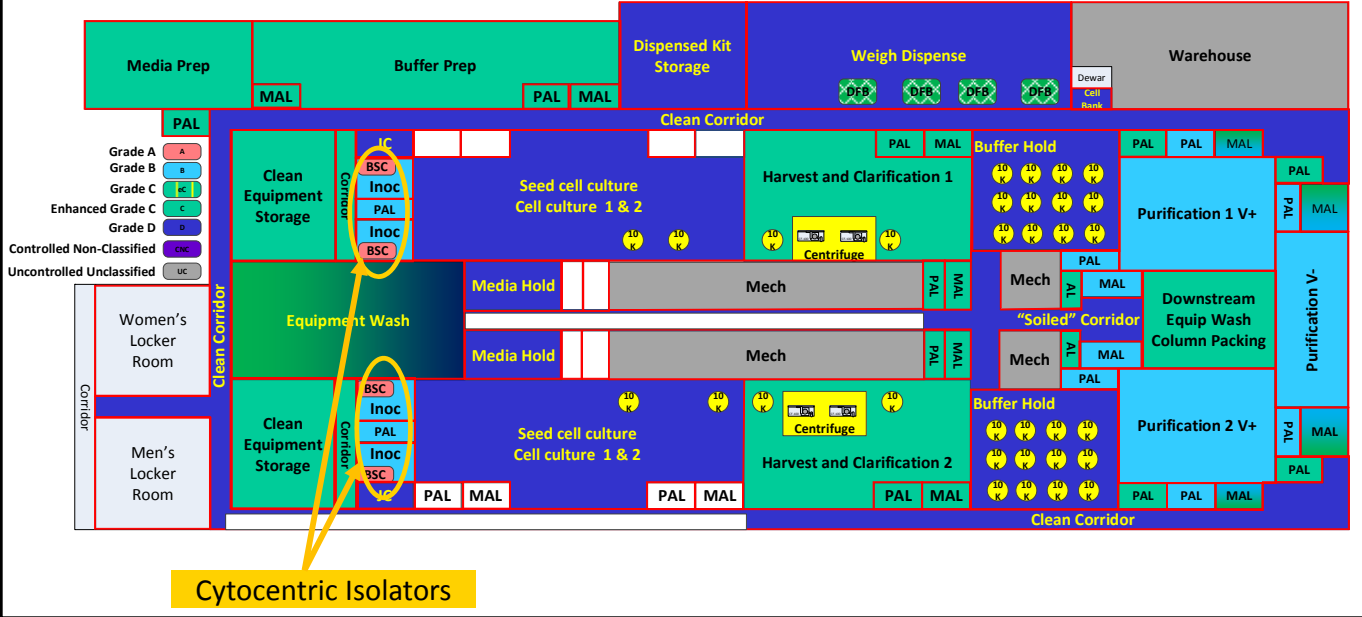

Closure Analysis / Risk Assessment

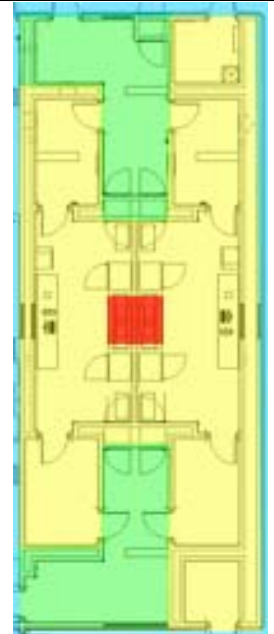
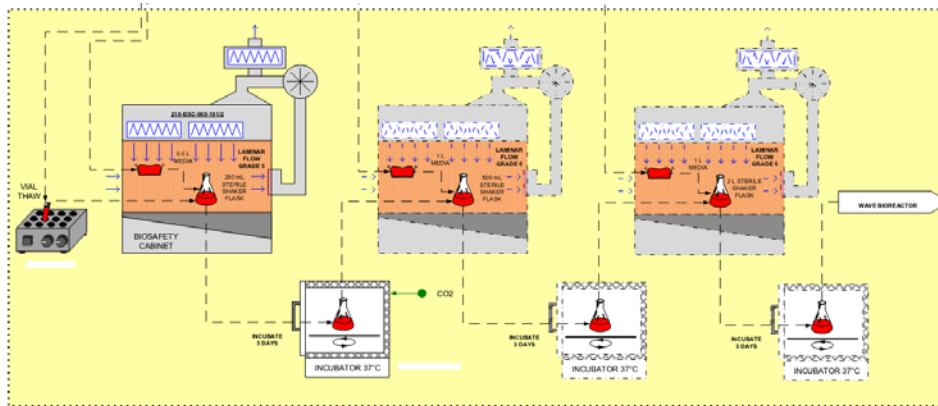

Cytocentric Isolator



- Grade A in Grade D or CNC
- Isolated from personnel
- Incubator: 37°, O₂, CO₂ control
- 100% Monitoring
- Located in Cell Culture Suite
- No Gowning or A/L required

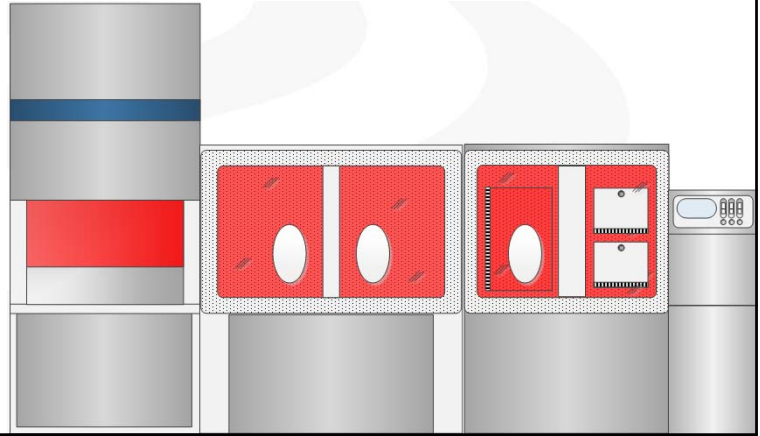

Closed Processing Thinking 1

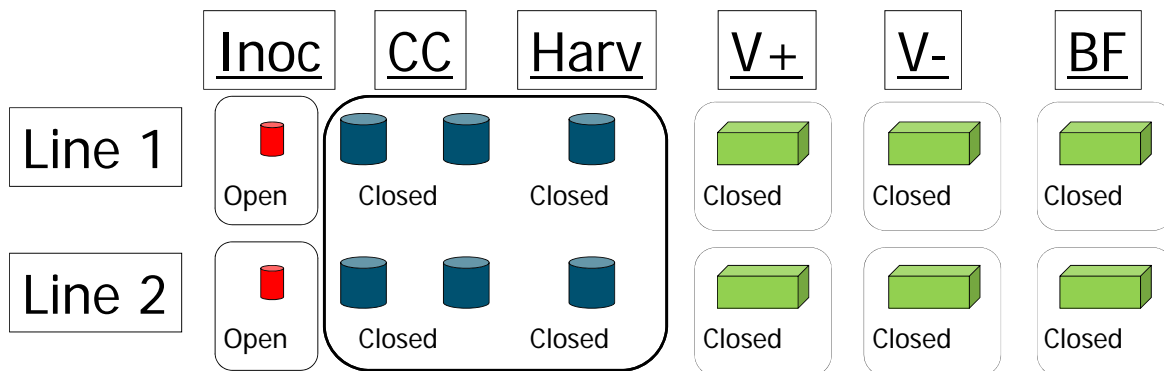

Closed Processing Thinking 1

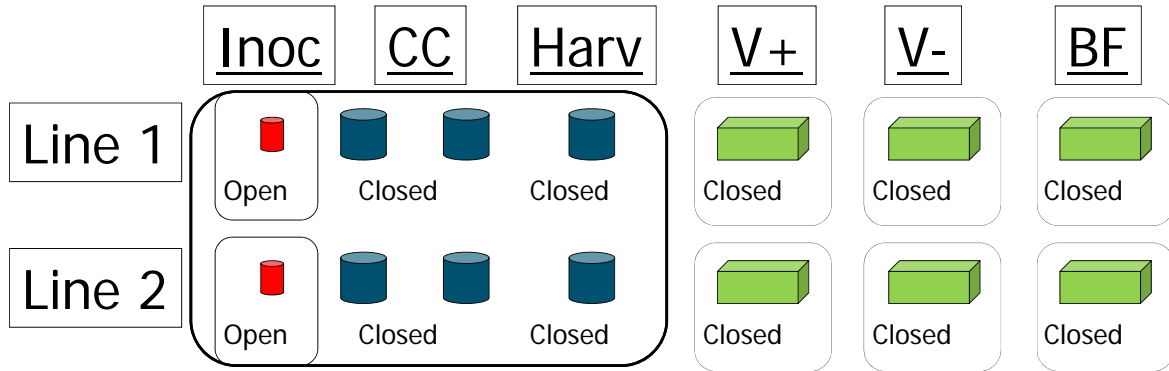

Impact of cytocentric isolators

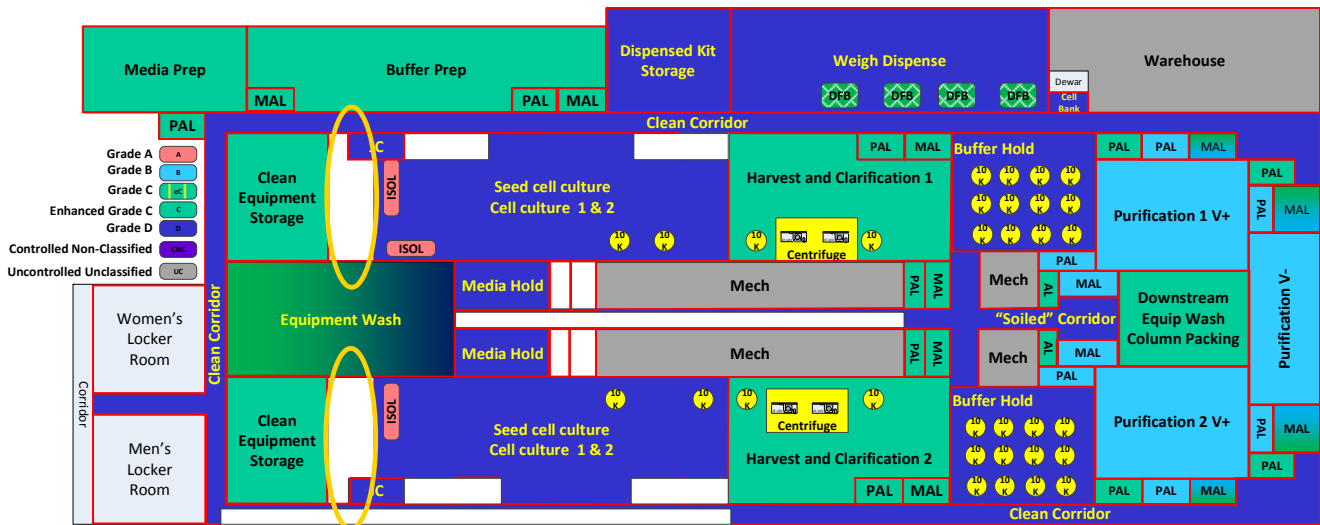

If Clarification is Briefly Exposed...

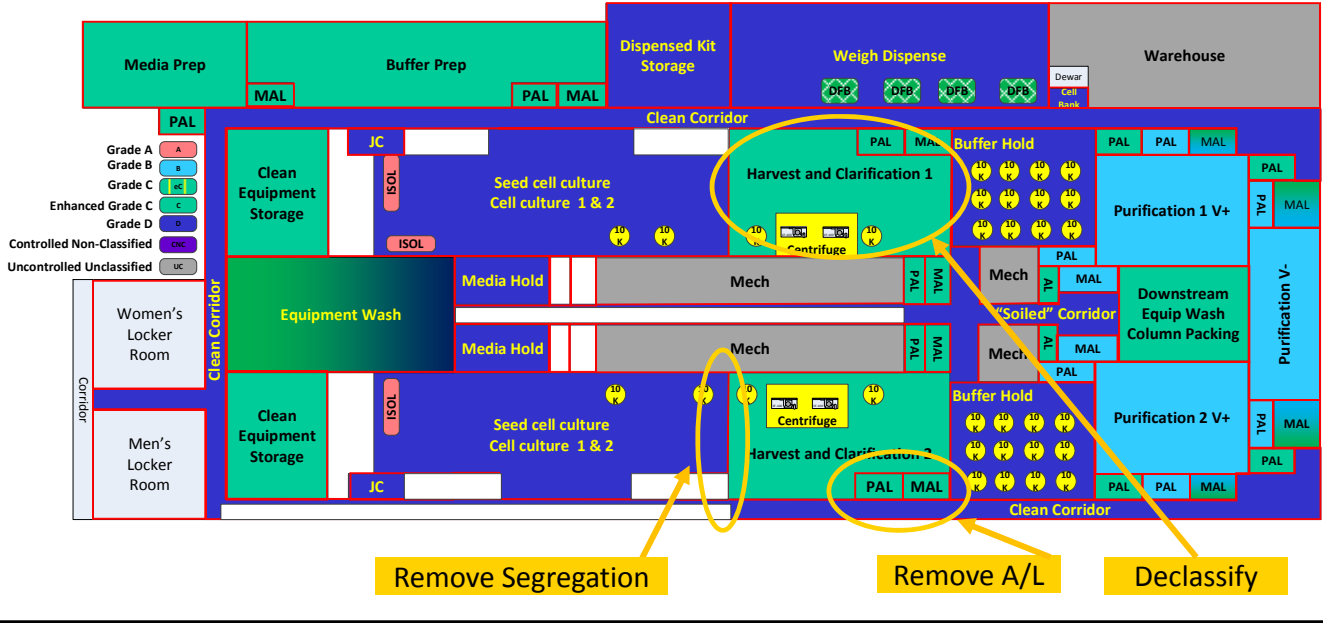

By combining clarification w sterile filtration

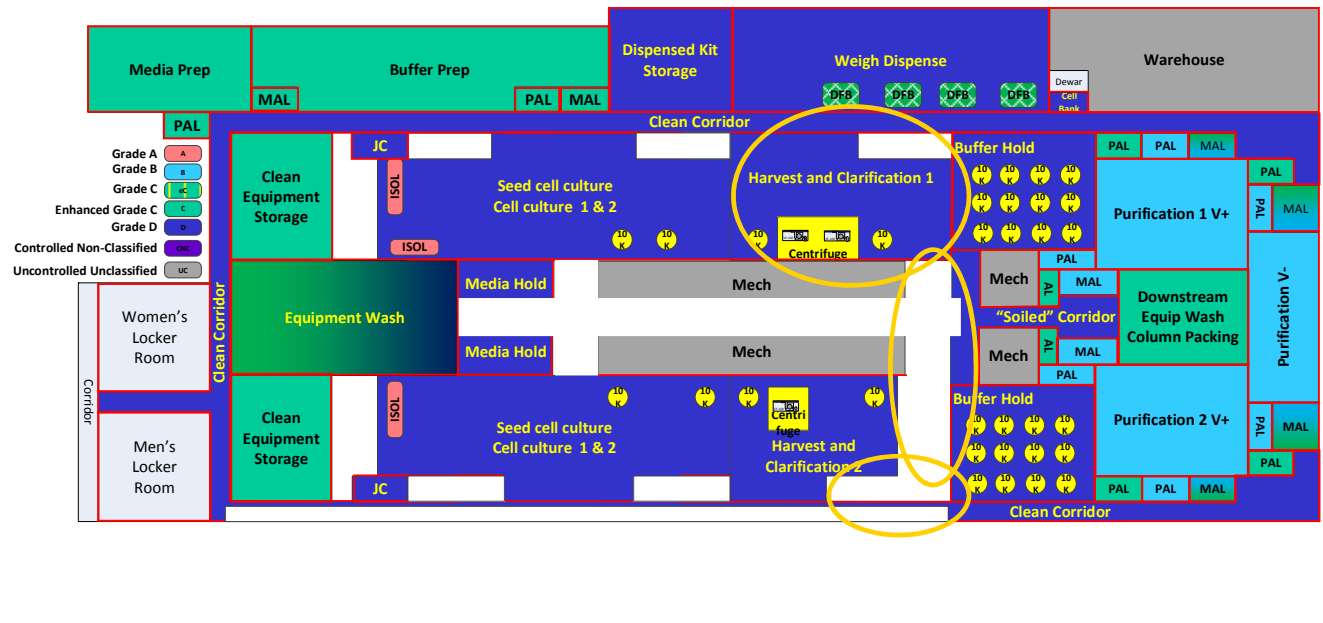

Consolidating Upstream

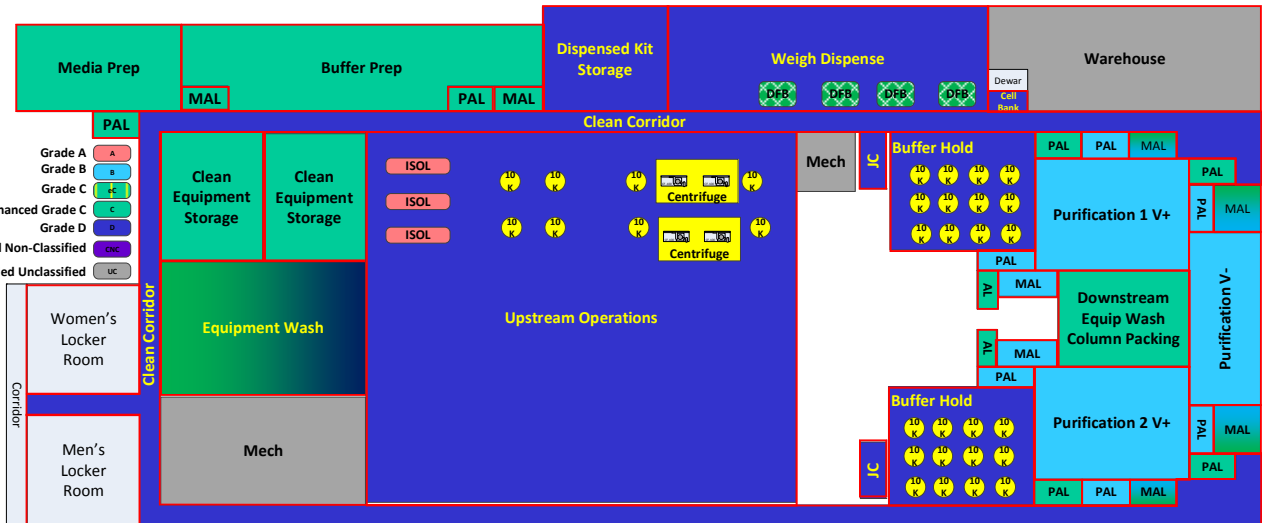

Closing Downstream Processing

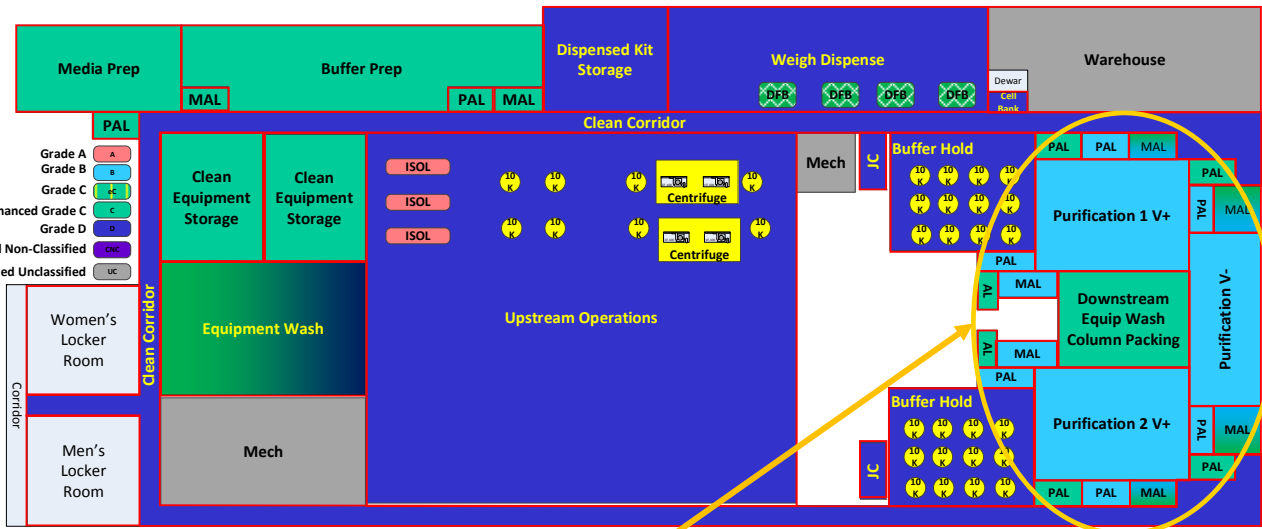

Can the same rules be applied?

Closed Processing Thinking 1→2

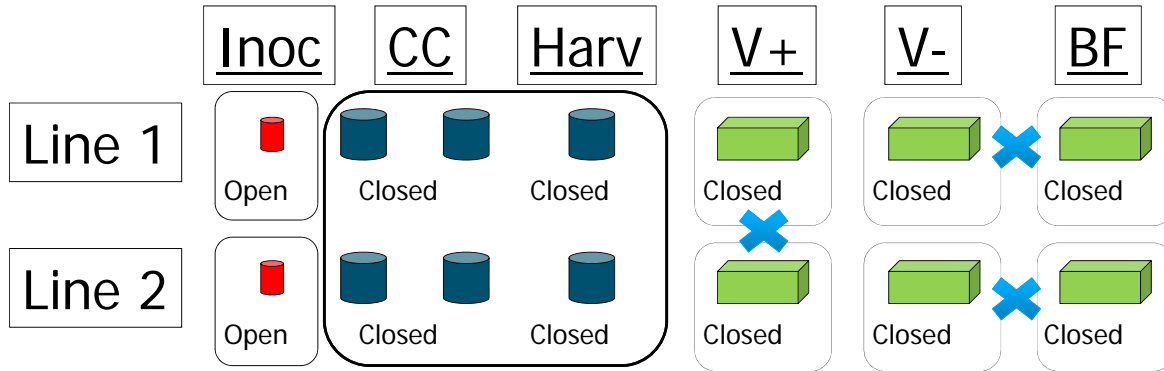

ANNEX 2

MANUFACTURE OF BIOLOGICAL MEDICINAL SUBSTANCES AND PRODUCTS FOR HUMAN USE

Item 12. Processing steps after harvesting may be carried out in the same production area provided that adequate precautions are taken to prevent cross contamination.

Closed Processing Thinking 2

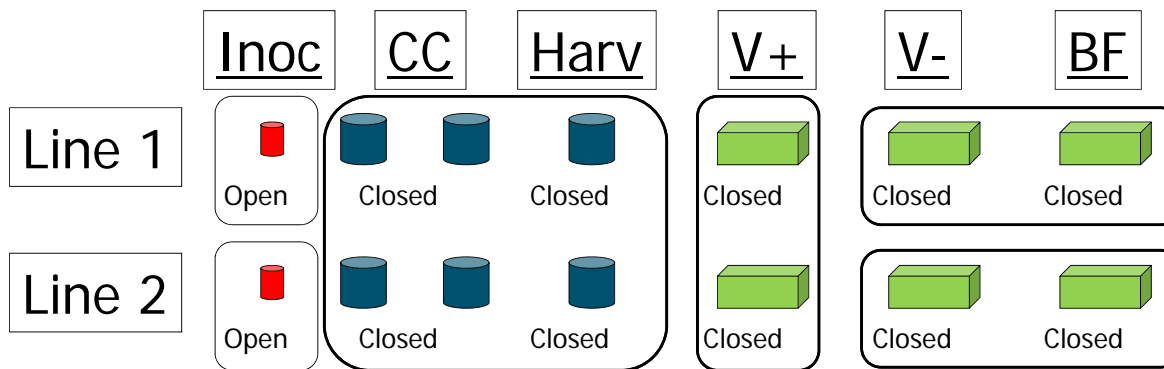

ANNEX 2

MANUFACTURE OF BIOLOGICAL MEDICINAL SUBSTANCES AND PRODUCTS FOR HUMAN USE

Item 12. Processing steps after harvesting may be carried out in the same production area provided that adequate precautions are taken to prevent cross contamination.

Closing Downstream Processing



**UF/DF
TFF**



**STERILE
FILTRATION**



CHROMATOGRAPHY



NANOFILTRATION



SAMPLING



Closing Downstream Processing



**TFF
SYSTEM
ASSEMBLY**



**NANOFILTRATION
PREPARATION**



CHROMATOGRAPHY

**RESIN SLURRY
ASSEMBLY
PACKING**



Closing Downstream Processing

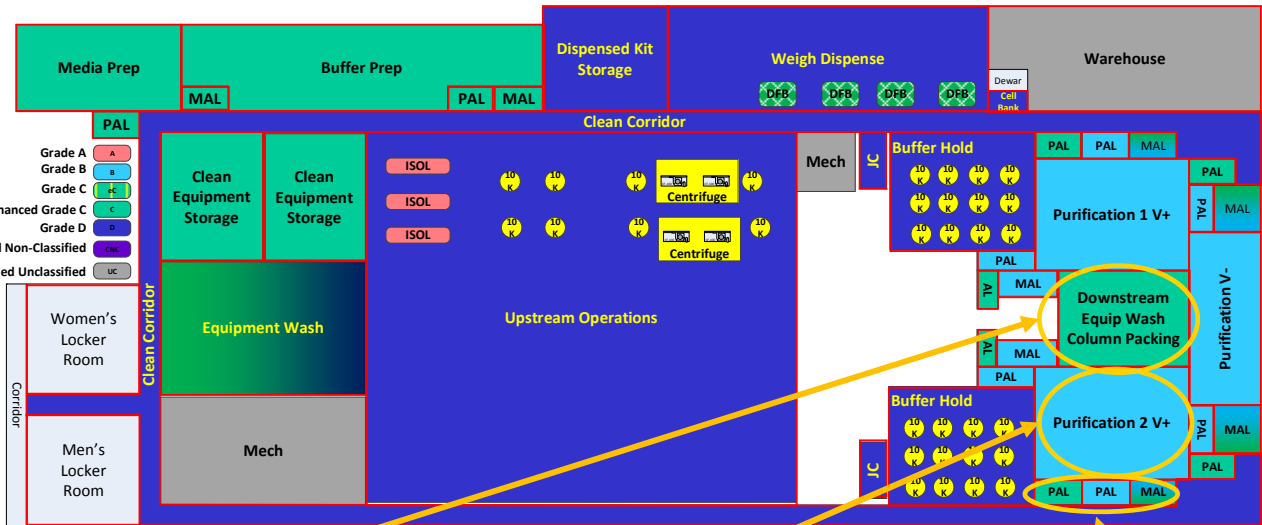

Classified area required for open operations

If closed, declassify

A/L no longer required

Closing Downstream Processing

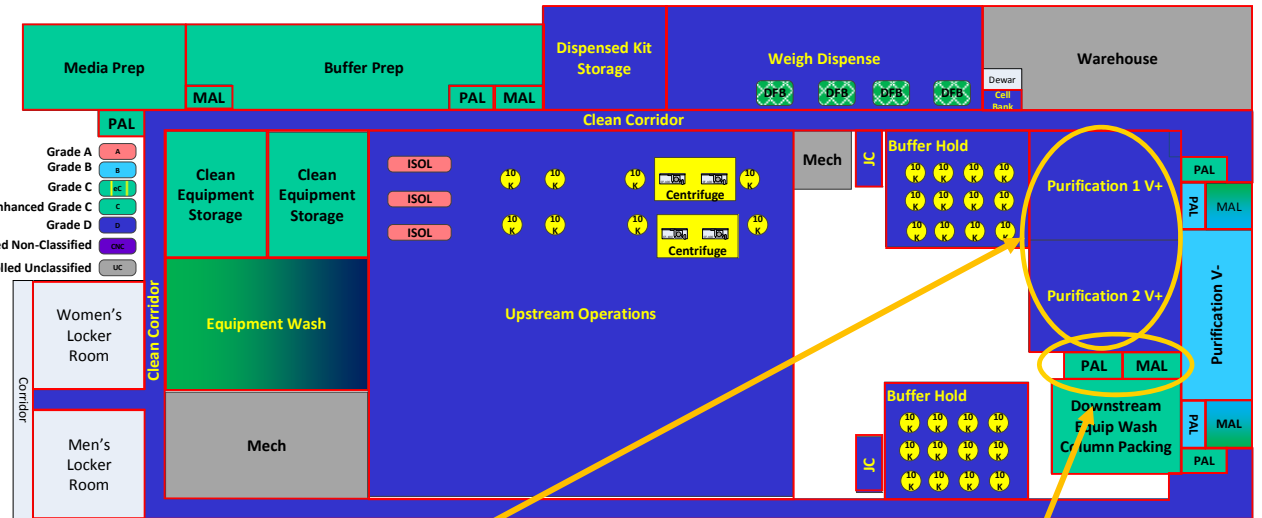

Consolidated spaces

A/L required for column packing area

Closing Downstream Processing

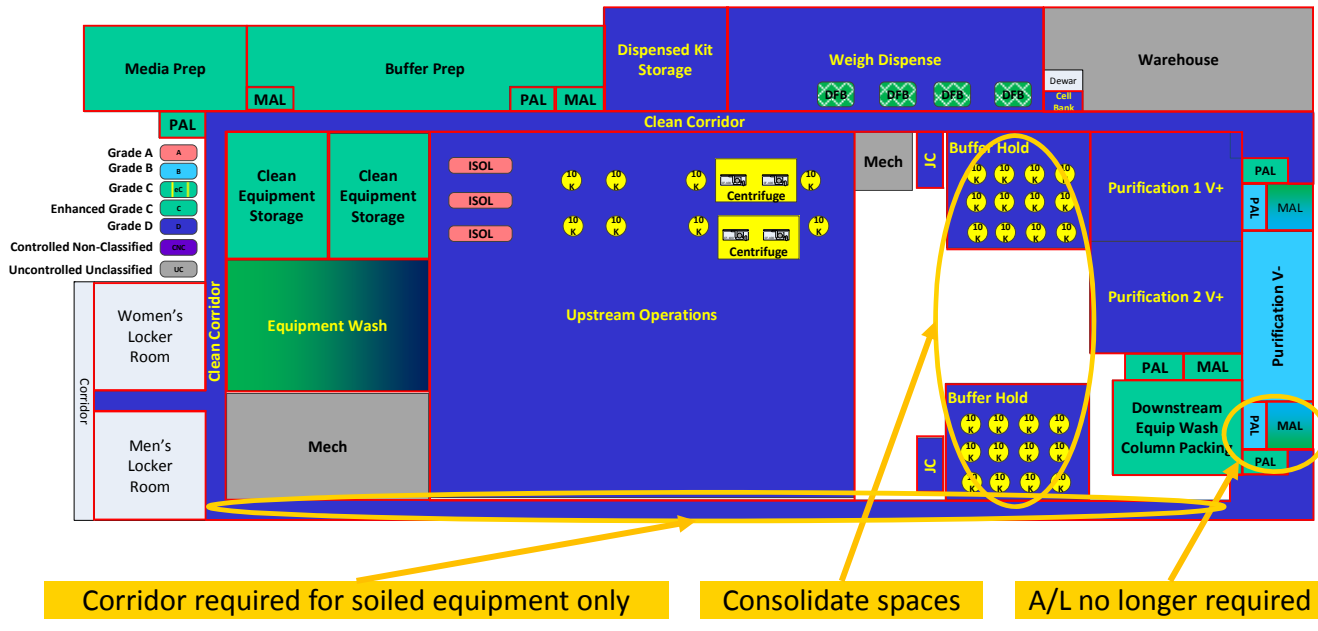

Closing Support Operations

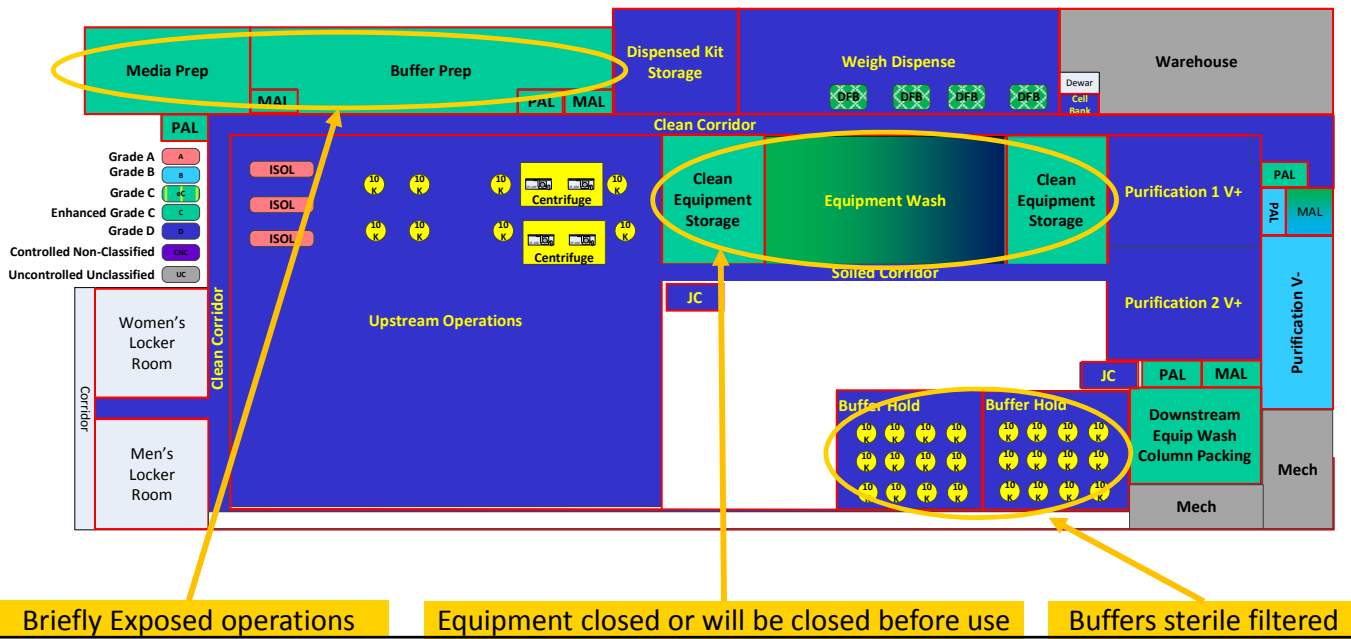

Closing Downstream Processing

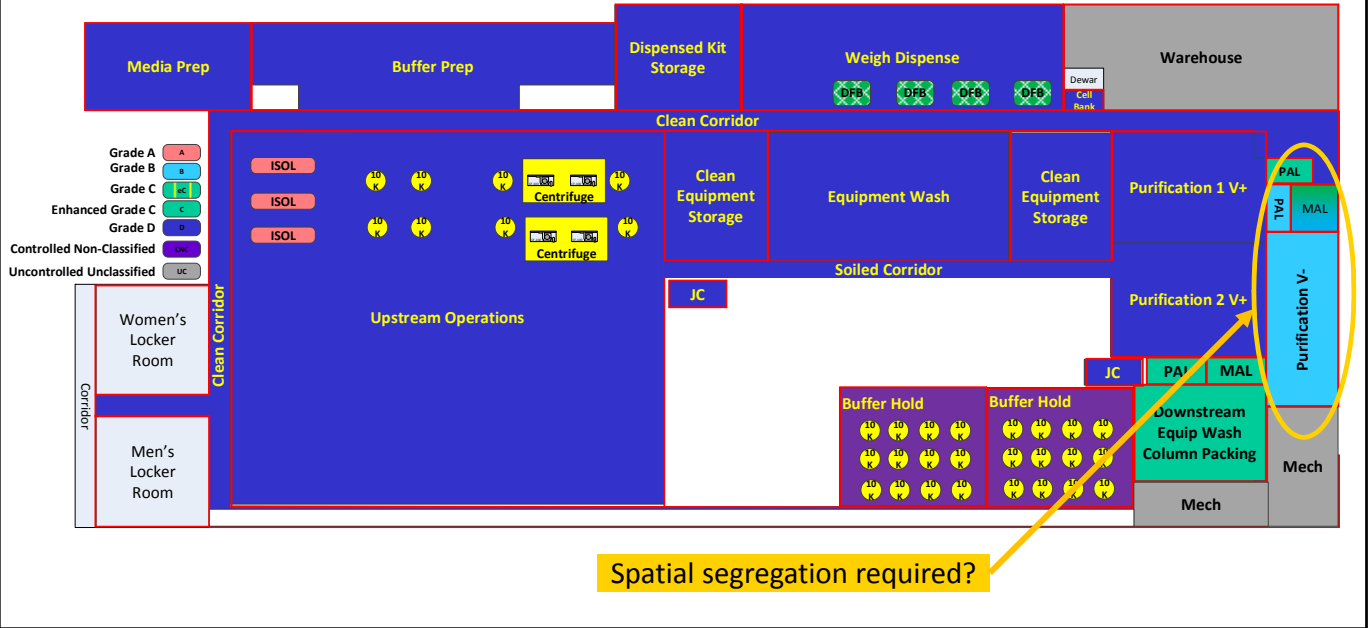

Impact of Closing BioProcessing

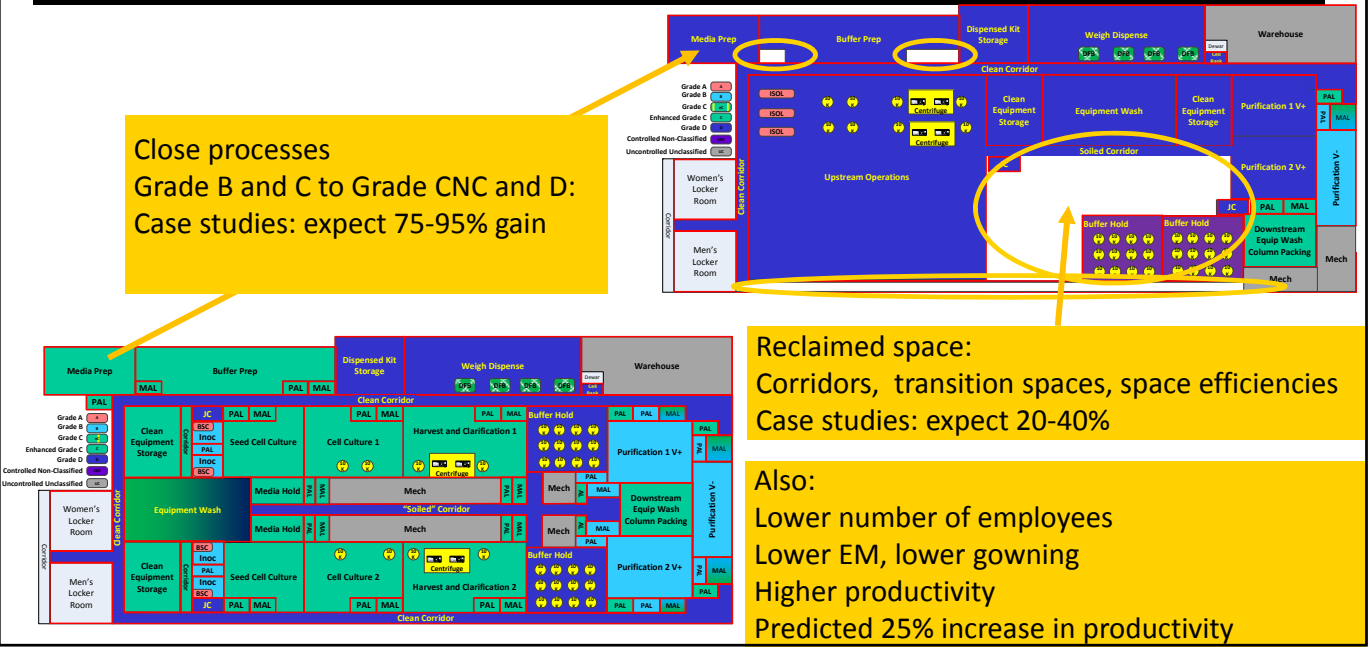



THE RELENTLESS PURSUIT OF SUCCESS. YOURS.™

Future Facility™

Other opportunities
Continuous Processing

Changing Manufacturing Strategies

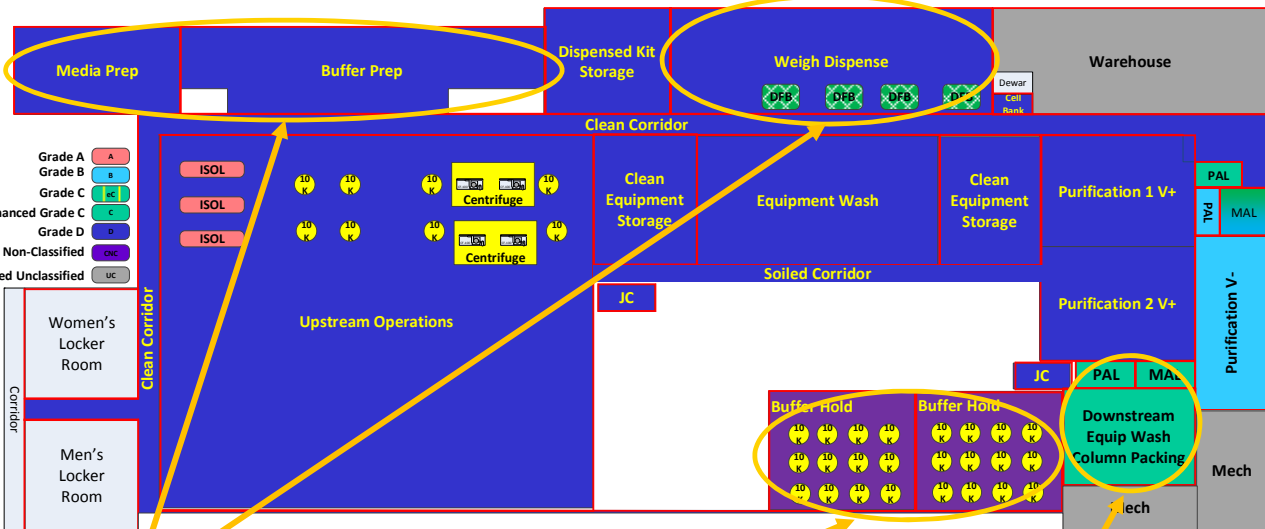

Off Site Preparation?

InLine Dilution?

Pre-Packed Columns?

Changing Manufacturing Strategies

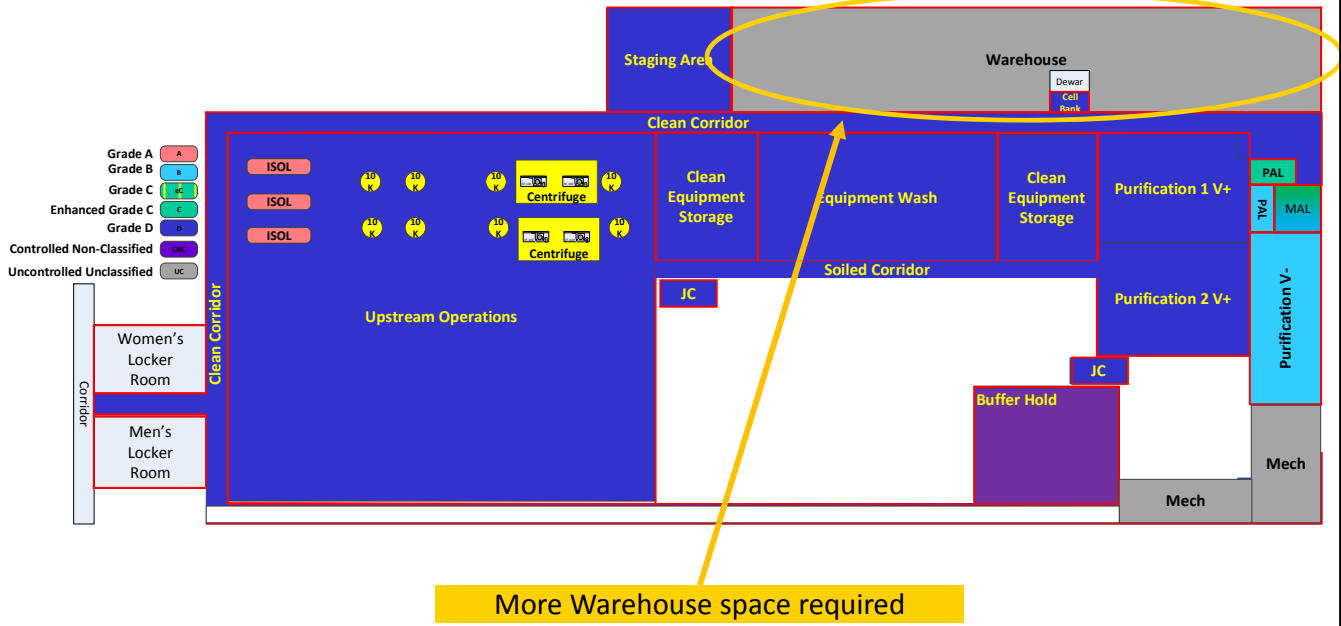

Changing Manufacturing Strategies

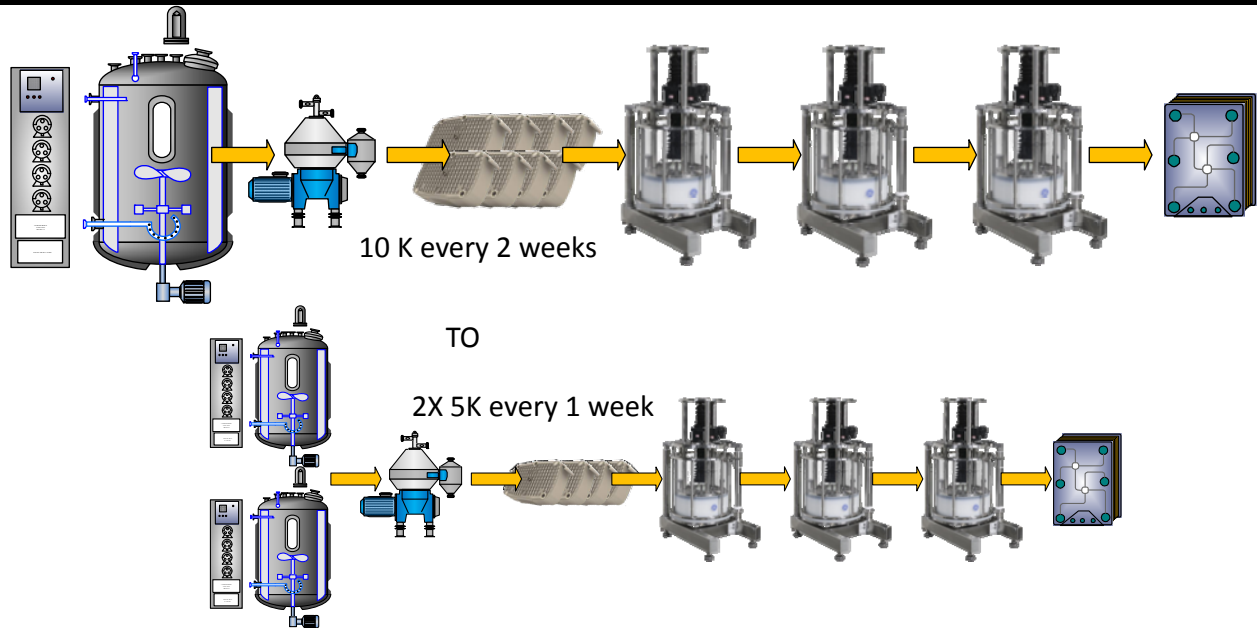

Changing Manufacturing Strategies

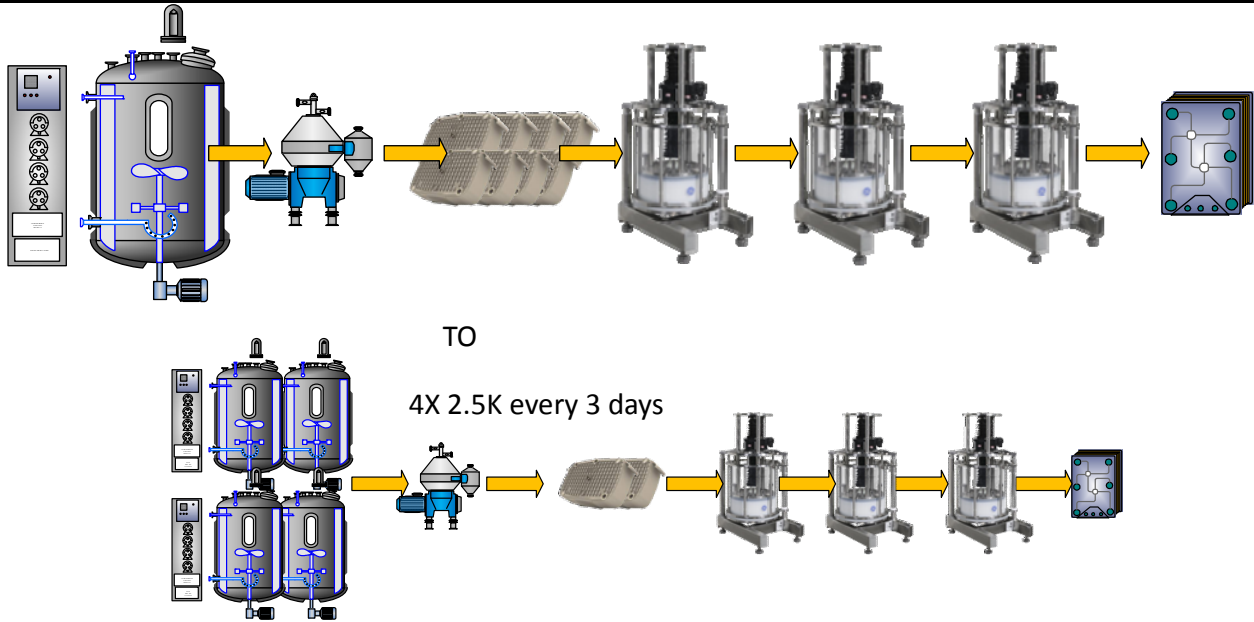

Changing Manufacturing Strategies

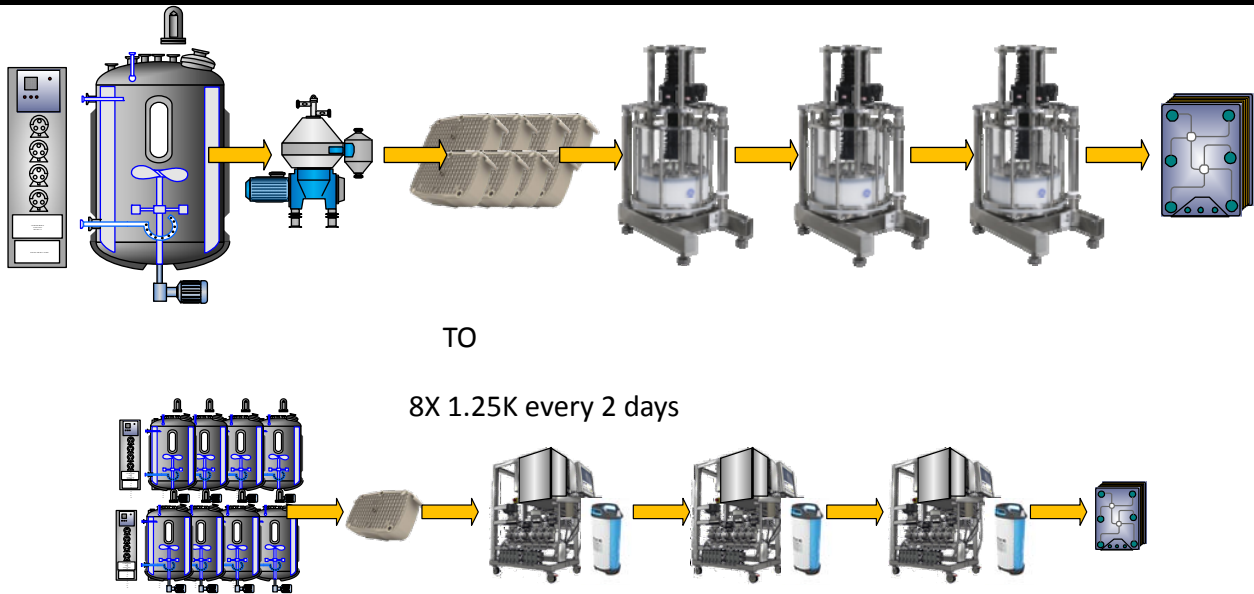

Changing Manufacturing Strategies

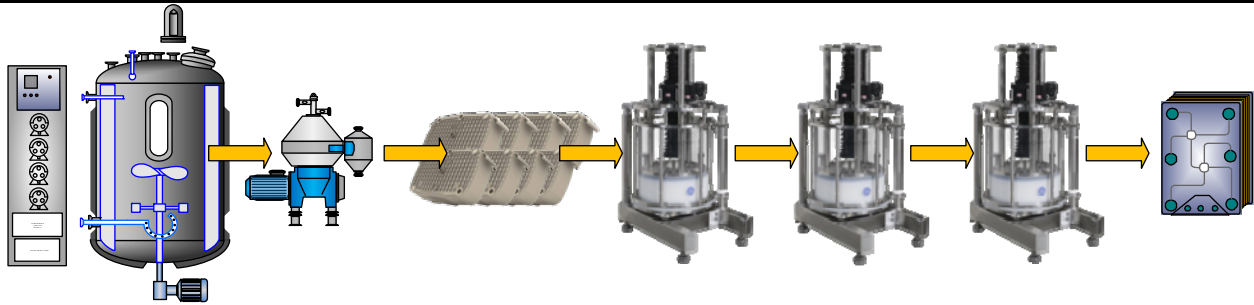

TO

Perfusion continuous



THE RELENTLESS PURSUIT OF SUCCESS. YOURS.™

Case Study

CONTINUOUS, CLOSED PROCESSING OF MAbs

PROCESS DEFINITION: 500 KG/Yr



	Traditional		FutureFacility
Vial Thaw / Scale-up			
N-3 (20 L)	Fed batch		
N-2 (100 L)	Fed batch	N-2 (20 L)	Thaw from cell bag
N-1 (500 L)	Fed batch	N-1 (200 L)	Perfusion – 50x10 ⁶ cells/mL
Prod BRX (2000 L)	Fed Batch - 4g/L	Prod BRX (2000 L)	Perfusion – 2g/L @ 1VVD
Harvest		Harvest	
Protein A Chromatography	1 x 60cm, 4 cycles	Protein A Chromatography	3 x 25cm, continuous
Viral Inactivation		Viral Inactivation	
Cation Chromatography	1 x 20cm, 5 cycles	Cation Chromatography	5 x 10cm, continuous
Anion Chromatography	1 x 60cm, 1 cycle	Anion Chromatography	4 x 10cm, continuous
Viral Filtration		Viral Filtration	4.5 day pool
UF/DF		UF/DF	
Bulk Fill		Bulk Fill	~ 325L

FACILITY SQ FT COMPARISON



Description of Space	Traditional (ft ²)	FF (ft ²)
Mechanical Space	46,975	17,543
Warehouse	8,905	5,200
Office	19,543	13,612
Lockers/Toilets	3,360	3,360
CNC space	18,298	10,283
Grade B/C space	14,666	1,382
TOTAL	111,747	51,380

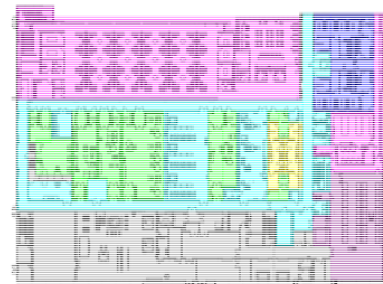

Productivity = 3.5 gram/yr/ sf



Productivity = 15.9 gram/yr/ sf

- Future Facility is 55% Smaller
- Future Facility is 4.6X more productive

TOTAL INSTALLED COST COMPARISON



Area	Traditional	Future Facility
Mechanical Space w/equipment	\$ 70,462,500	\$ 26,314,500
Warehouse	\$ 1,335,750	\$ 780,000
Office	\$ 2,931,450	\$ 2,041,800
Lockers/Toilets/Gowning	\$ 672,000	\$ 672,000
CNC space	\$ 4,757,480	\$ 2,673,580
ISO 8 space	\$ 7,113,010	\$ 760,100
Process Equipment / Installation	\$ 22,070,676	\$ 15,941,505
Total Direct Cost Facility	\$ 109,342,866	\$ 49,183,485

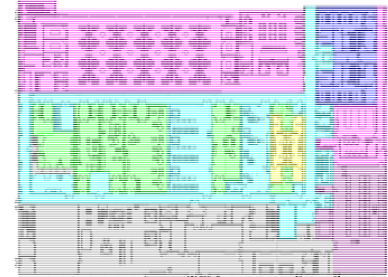

\$ 978 / SF

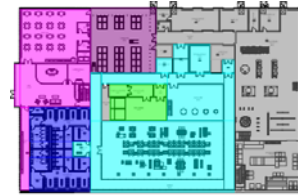

\$ 957 / SF

COST OF GOODS (COGs)

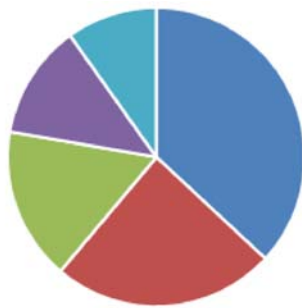

Traditional
\$145 / gram

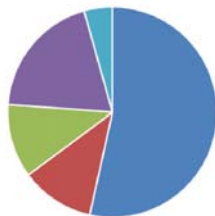

Future Facility
\$69 / gram

	Batch \$/gm	Continuous \$/gm	
Raw Materials	53.51	36.96	*
Energy / Utilities	35.19	7.85	
Labor	24.00	7.79	**
Consumables	18.00	13.47	
Annual Depreciation	14.29	3.02	
TOTAL	144.99	69.08	

* = Higher media costs with Perfusion

** = Headcount reduction from 68 to 47



THE RELENTLESS PURSUIT OF SUCCESS. YOURS.™

Future Facility™

What is it?

FutureFacilitySM



Incorporate best of latest technologies, design philosophies, and compliance strategies

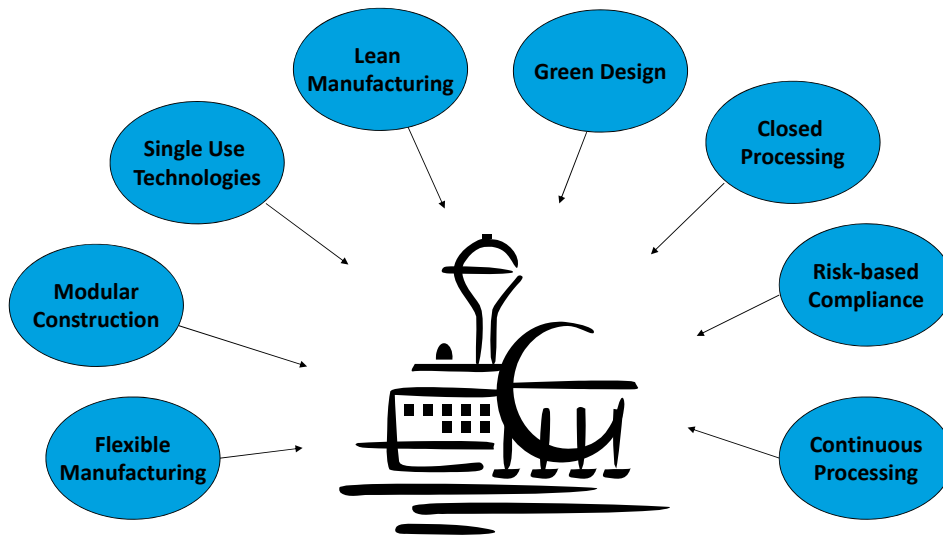

Closed + Continuous = Low Cost

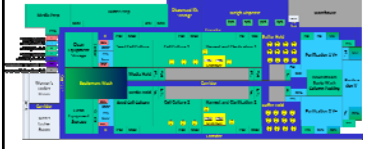

Less competitive
Higher cost
Less flexible

Facility Cost
Project Risk

Lower cost
More competitive
Highly flexible

